

Technical Data Sheet

SONOFLOW CO.55 V3.0

**Ultrasonic Flow Sensor
for Non-Invasive Flow Measurement**

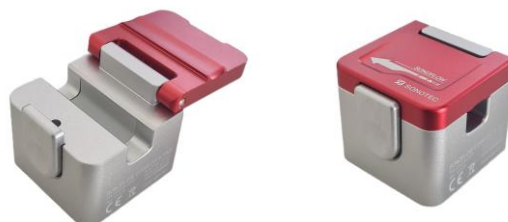

SONOFLOW CO.55 V3.0 clamp-on flow meters measure the flow rate of liquids in flexible tubes of different diameters and include reliable bubble detection for enhanced process monitoring. With high accuracy, reproducibility and repeatability – even in the lowest flow range – the sensors are suited for a variety of applications. Various accessories allow for easy integration into bench top setups and industrial process environments.

Accuracy

Sensor variant with cover clasp

SONOFLOW type	Accuracy (of reading) on specified tubing ¹		Typical flow range ²
	Low flow range	High flow range	
CO.55/0250 V3.0	0 ... 150 ml/min: ± 1.5 ml/min	> 150 ml/min: ± 1 %	0 ... 1 000 ml/min
CO.55/0375 V3.0	0 ... 300 ml/min: ± 3 ml/min	> 300 ml/min: ± 1 %	0 ... 4 000 ml/min
CO.55/0438 V3.0	0 ... 450 ml/min: ± 4.5 ml/min	> 450 ml/min: ± 1 %	0 ... 4 500 ml/min
CO.55/0500 V3.0	0 ... 500 ml/min: ± 5 ml/min	> 500 ml/min: ± 1 %	0 ... 5 000 ml/min

Sensor variant with handle (H)

SONOFLOW type	Accuracy (of reading) on specified tubing ¹		Typical flow range ²
	Low flow range	High flow range	
CO.55/0625H V3.0	0 ... 700 ml/min: ± 7 ml/min	> 700 ml/min: ± 1 %	0 ... 10 000 ml/min
CO.55/0750H V3.0	0 ... 1 000 ml/min: ± 10 ml/min	> 1 000 ml/min: ± 1 %	0 ... 15 000 ml/min
CO.55/1000H V3.0	0 ... 3 500 ml/min: ± 35 ml/min	> 3 500 ml/min: ± 1 %	0 ... 30 000 ml/min
CO.55/1125H V3.0	0 ... 4 000 ml/min: ± 40 ml/min	> 4 000 ml/min: ± 1 %	0 ... 40 000 ml/min
CO.55/1375H V3.0	0 ... 6 000 ml/min: ± 60 ml/min	> 6 000 ml/min: ± 1 %	0 ... 80 000 ml/min

1) Accuracy based on standard calibration conditions as listed. Accuracy depends on tubing, tubing variations, temperature, fluid properties, clamping and other conditions (design of inlet and outlet section).

The specified accuracy values are based on standardized test conditions. Depending on the application, accuracy – especially in the lower flow range – may be further improved by on-site adjustments. For further questions, please contact our sales team.

2) Maximum flow: limited by tubing and pump capacity only.

Calibration conditions

Sensors are factory calibrated under the following standard conditions:

- Tubing as listed in table 'Tubing properties', not sterilized
- Water at 23 °C ± 2 K
- Warm up: at least 30 min
- Zero calibration after clamp-on
- Open tubing outlet (pressure close to zero)

Besides recalibrations of our flow sensors we offer safety inspections and repair service for all our products. Contact us!

Tubing properties

Typical types of tubes are listed below. The sensors are also suitable for comparable flexible tubes (different tube manufacturers, diameters, materials such as PVC, TPE, etc.). If possible, provide a tubing sample (minimum length 75 cm) along with your order.

Sensor variant with cover clasp

Tube type:

Masterflex® precision pump tubing, platinum-cured silicone, not sterilized*

SONOFLOW type	Tubing ID	Tubing OD	Tubing details from the manufacturer	
CO.55/0250 V3.0	1/8" [0.125"]	1/4" [0.250"]	L/S® 16	Item No. 96410-16
CO.55/0375 V3.0	1/4" [0.250"]	3/8" [0.375"]	L/S® 17	Item No. 96410-17
CO.55/0438 V3.0	1/4" [0.250"]	7/16" [0.438"]	L/S® 24	Item No. 96410-24
CO.55/0500 V3.0	5/16" [0.313"]	1/2" [0.5"]	L/S® 35	Item No. 96410-35

Sensor variant with handle (H)

Tube type:

Masterflex® precision pump tubing, platinum-cured silicone, not sterilized* (A)

Saint-Gobain® C-Flex® tubing, thermoplastic elastomer (TPE), not sterilized* (B)

SONOFLOW type	Tubing ID	Tubing OD	Tubing details from the manufacturer		
CO.55/0625H V3.0	3/8" [0,375"]	5/8" [0,625"]	I/P® 73	Artikel-Nr. 96410-73	(A)
CO.55/0750H V3.0	1/2" [0,5"]	3/4" [0,75"]	I/P® 82	Artikel-Nr. 96410-82	(A)
CO.55/1000H V3.0	3/4" [0.75"]	1"	374	Item No. 374-750-4	(B)
CO.55/1125H V3.0	3/4" [0.75"]	1 1/8" [1.125"]	374	Item No. 374-750-6	(B)
CO.55/1375H V3.0	1"	1 3/8" [1.375"]	374	Item No. 374-1000-6	(B)

* Gamma sterilization, x-ray sterilization, or autoclaving of the tubing may impact its material properties, potentially affecting sensor readings. Recalibration may be required after tubing sterilization.



Bubble detection feature

Ultrasonic amplitude attenuation is used to detect bubbles in the flow. The default detection threshold is set to enable detection of bubbles with a size of approximately $\geq 1/3 \times$ the tubing inner diameter (ID).

In the optimal installation orientation (lid to side), bubbles $\geq 1/3 \times$ ID are reliably detected. In other installation orientations (lid to top or lid to bottom), detection sensitivity may vary depending on application conditions. In these orientations, bubbles are detected in the range of $\geq 1/3$ to $1/2 \times$ ID, with reliable detection ensured for bubbles $\geq 1/2 \times$ ID.

The detection status is available via RS-485 and via the configurable switching output.

Installation Orientation vs. Bubble Detection Sensitivity*

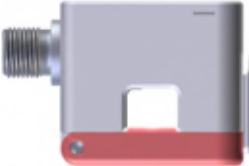
Installation orientation	Illustration (side view)	Detectable bubble size
Lid to side (optimal)		$\geq 1/3 \times$ ID
Lid to top		$\geq 1/3-1/2 \times$ ID
Lid to bottom		$\geq 1/3-1/2 \times$ ID

* Detection limits refer to controlled test and calibration conditions using the standard tubing dimensions specified in this data sheet (ID/OD). Detection performance may vary depending on tubing material, mounting conditions, and application parameters such as pulsation, pressure variation, or flow turbulence. For tubing with deviating inner diameter (ID), suitability must be verified by the user.

Sensor interfaces

Interface	Specifications
Current output	0 (4) ... 20 mA Resolution: < 1 μ A Update rate: up to 1 kHz Configurable for flow range Load to GND. The max. load depends on the operating voltage: 12 V \rightarrow 250 Ω 15 V \rightarrow 500 Ω 24 V \rightarrow 1 k Ω 30 V \rightarrow 1.2 k Ω
RS-485 interface	RS-485 bus operation: max. 12 subscribers Default address: #01 Available protocols: <ul style="list-style-type: none">• SONOTEC protocol: Half-duplex operation 115 200 baud No parity 1 stop bit no handshaking• Modbus[®] protocol: configurable settings via software Provides, e.g.: <ul style="list-style-type: none">• Readout of flow, volume and status information (incl. bubble status)• Parameter configuration• Access to diagnostic data
Switching output	Switching characteristics: PNP / NPN / Push-pull 0 ... 30 V max. 100 mA PWM output period: 0.1 ms ... 1 000 ms Output range 0 ... 100 % or 5 ... 95 % Smallest pulse length: 5 μ s Configurable as: <ul style="list-style-type: none">• Volume switch (adapting batch process / dosing)• Threshold switch of flow• Pulses of volume (flexible pulse length, max. 20 kHz)• Flow rate (via frequency or duty cycle)• Status information via switch• Bubble alarm
Digital input	Internal pull-up to operating voltage (100 k Ω) Voltage resistant up to 30 V Configurable for: <ul style="list-style-type: none">• Zero point calibration of flow• Start dosing processes (reset volume) (Either separate or simultaneous execution possible)

Electrical specifications and connections

Parameter	Specifications
Operating voltage	12 ... 30 VDC Protection against reverse-polarity (external fuse, if required: min. 200 mA)
Current consumption	Maximum 60 mA (with open current, frequency and switching output, depending on supply voltage) Inrush current (during start-up < 10 ms): < 350 mA at 12 V, < 150 mA at 24 V
Electrical connection	8-pin M12 connector DIN EN 61076-2-101:2012

8 pin connector to 8 pole cable

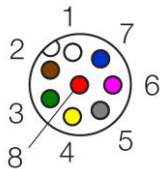
Connection	Pin	Assignment	Color
 <p>Male connector (at the sensor)</p>	1	Ground	White
	2	Operating voltage	Brown
	3	Current output	Green
	4	RS-485 B	Yellow
	5	RS-485 A	Gray
	6	(not assigned)	Pink
	7	Switching output / frequency output	Blue
	8	Digital input	Red
Shielding	Cable shield must be connected to housing		

General data

Parameter	Specifications
Measuring method	Flow and Volume: Ultrasonic time of flight measurement Bubble Detection: Signal amplitude attenuation
Sensor materials	Measuring channel: ABS Housing: anodized aluminum Connector: stainless steel
Mounting	4 threaded mounting holes (see 'Technical drawings')
Maintenance	Maintenance-free
Directives and standards	<ul style="list-style-type: none">• EMC Directive 2014/30/EU• RoHS Directive 2011/65/EU, exception: III 7cl/ IV 15; RoHS 2015/863• Acoustic emission: IEC 61157:2007 + A1:2013

Conditions of use

Parameter	Specifications
Customized calibration	Standard calibration according to factory specification. Calibration to deviating, flexible customer tubing, fluid, flow range, temperature, etc. on request.
Operating conditions	Adaptation to different tubes or operating conditions by parameter settings (with the help of optionally available software).
Media	Water or similar liquids
Ambient- / Media temperature	0 ... 60 °C (other temperatures available on request)
Storage temperature	-20 ... +70 °C
Degree of protection	IP65

Scope of supply and accessories

Parameter	Specifications		
Scope of supply	<ul style="list-style-type: none"> • Sensor SONOFLOW CO.55 V3.0 according to specification • User documentation • Calibration report 		
Optional accessories	<p>Software: Adjusting parameters, recording measurement data, updating the sensor software</p> <hr/> <p>Software variants:</p> <table border="0"> <tr> <td> <p>Monitor software set for SONOFLOW CO.55 / IL.52, consisting of</p> <ul style="list-style-type: none"> • Flow Monitor software package • USB data converter, type 013 • USB cable, type A - B, 2 m • Connecting cable, M12 connector: 8-pole, 2 m • Switching power supply, 12 V, incl. international plug adapters • User documentation </td> <td> <p>Monitor software set for SONOFLOW CO.55/IL.52 portable, consisting of</p> <ul style="list-style-type: none"> • Flow Monitor software package • Portable USB data converter, type 023 • User documentation </td> </tr> </table> <hr/> <p>Portable USB Data Converter Type 023 for</p> <ul style="list-style-type: none"> • Mobile operation of sensors via a standard USB power socket or power bank • Triggering of functions stored for the digital sensor input ('push button switch') <hr/> <p>Remote Display RD.10 including connecting cable for</p> <ul style="list-style-type: none"> • Monitoring sensor performance (display e.g. current flow rate, volume or measuring state) • Zero calibration • Manual volume reset <hr/> <p>EtherNet/IP Gateway programmed for SONOTEC</p> <ul style="list-style-type: none"> • Serial communication with an EtherNet/IP-based system (e.g. PLC) • Support of up to 12 sensors • Pre-configured parameters and commands (library with Modbus registers for time-saving installation) 	<p>Monitor software set for SONOFLOW CO.55 / IL.52, consisting of</p> <ul style="list-style-type: none"> • Flow Monitor software package • USB data converter, type 013 • USB cable, type A - B, 2 m • Connecting cable, M12 connector: 8-pole, 2 m • Switching power supply, 12 V, incl. international plug adapters • User documentation 	<p>Monitor software set for SONOFLOW CO.55/IL.52 portable, consisting of</p> <ul style="list-style-type: none"> • Flow Monitor software package • Portable USB data converter, type 023 • User documentation
<p>Monitor software set for SONOFLOW CO.55 / IL.52, consisting of</p> <ul style="list-style-type: none"> • Flow Monitor software package • USB data converter, type 013 • USB cable, type A - B, 2 m • Connecting cable, M12 connector: 8-pole, 2 m • Switching power supply, 12 V, incl. international plug adapters • User documentation 	<p>Monitor software set for SONOFLOW CO.55/IL.52 portable, consisting of</p> <ul style="list-style-type: none"> • Flow Monitor software package • Portable USB data converter, type 023 • User documentation 		

Sensor dimensions and technical drawings

Drawings are not to scale. Dimensions in mm, unless otherwise specified.
 Design data (STEP files) for integration will be provided upon request. Please contact us.

Sensor variant with cover clasp

SONOFLOW type	Product No	Dimensions (L x W x H)	Mounting holes	Mounting hole spacing	Weight (approx.)
CO.55/0250 V3.0	200 08 0198	44 x 44 x 37 mm	M4 x 8 mm	36 mm	140 g
CO.55/0375 V3.0	200 08 0199	44 x 44 x 37 mm	M4 x 8 mm	36 mm	140 g
CO.55/0438 V3.0	200 08 0170	44 x 44 x 38 mm	M4 x 8 mm	36 mm	140 g
CO.55/0500 V3.0	200 08 0200	44 x 44 x 39 mm	M4 x 8 mm	36 mm	140 g

Size	H	CW	CH
/0250	37	6,3	5,2
/0375	37	9,5	6,6
/0438	38	11,1	8,8
/500	39	12,7	9,8

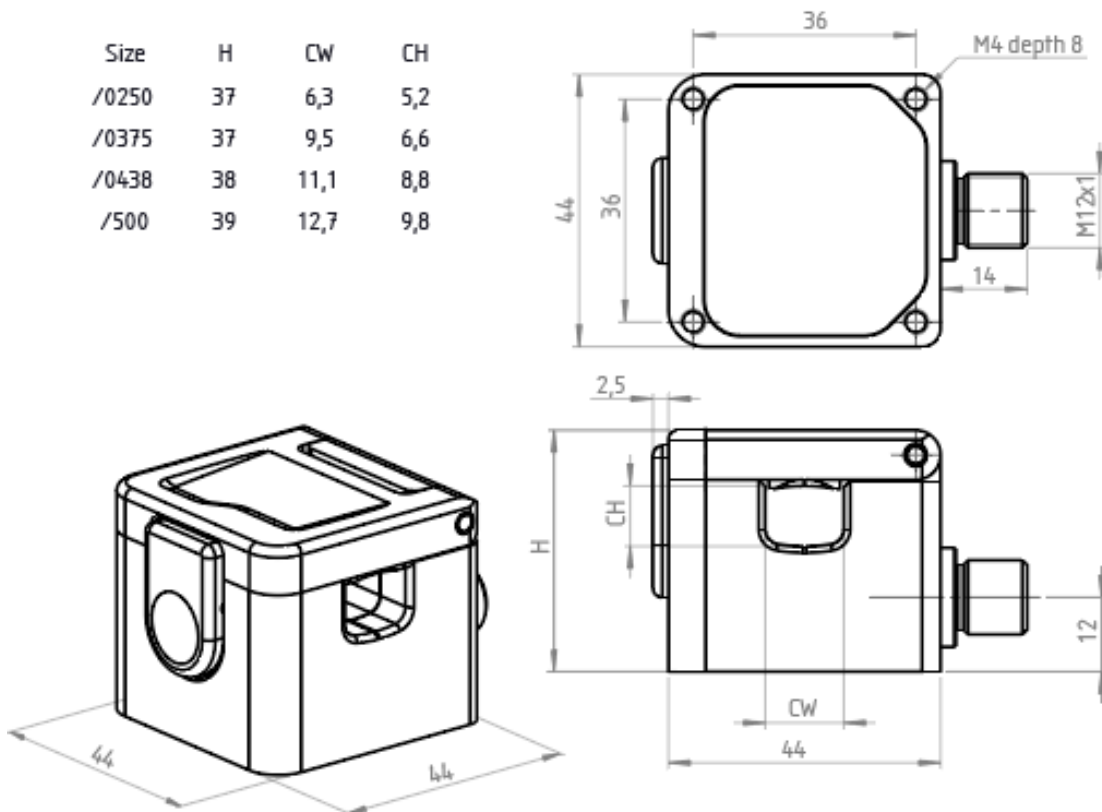

Sensor variant with handle (H)

For applications on tubes with large outer diameters, the corresponding sensors are equipped with a locking screw (handle) to assist handling when inserting the tube.

SONOFLOW type	Product No	Dimensions (L x W x H) [Height with handle]	Mounting holes	Mounting hole spacing	Weight (approx.)
CO.55/0625H V3.0	200 08 0175	66 x 66 x 66 mm	M6 x 8 mm	55 mm	450 g
CO.55/0750H V3.0	200 08 0177	66 x 66 x 68 mm	M6 x 8 mm	55 mm	450 g
CO.55/1000H V3.0	200 08 0171	66 x 66 x 54 [75] mm	M6 x 8 mm	55 mm	450 g
CO.55/1125H V3.0	200 08 0173	66 x 66 x 57 [78] mm	M6 x 8 mm	55 mm	450 g
CO.55/1375H V3.0	200 08 0209	66 x 66 x 62 [83] mm	M6 x 8 mm	55 mm	450 g

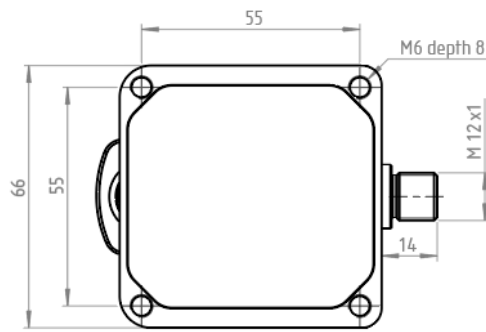
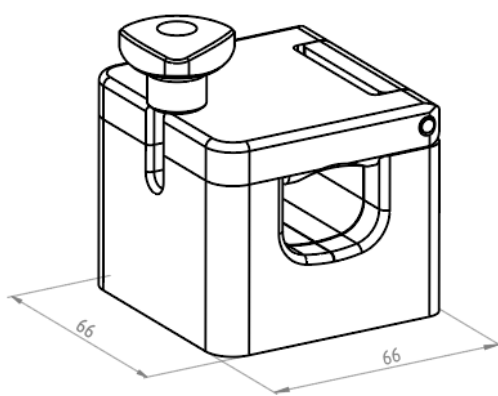

Size	H	HWH	CW	CH
/0625	45	65,5	15,8	12
/0750	47	67,5	19,0	15,4
/1000	54	74,5	25,4	20,5
/1125	57	77,5	28,5	22,5
/1375	62	82,5	35	27

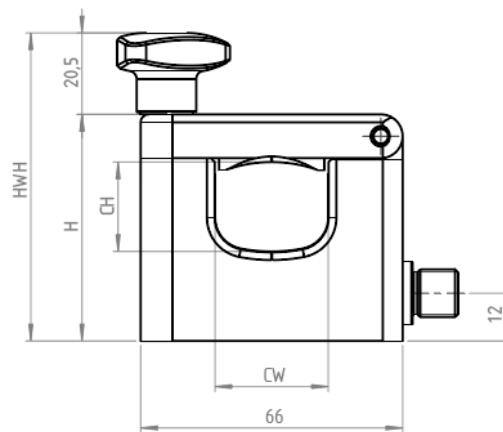

Information is subject to change without notice. Latest published version of this documentation online. SONOTEC is a registered trademark.



Manufacturer

SONOTEC GmbH
Headquarters Site 2
Thüringer Str. 33 Nauendorfer Str. 2 Tel.: +49 345 13317-0
06112 Halle (Saale) 06112 Halle (Saale) sonotec@sonotec.de
Germany www.sonotec.eu

Contact USA

SONOTEC US Inc.
10 Newton Pl., Ste. 100 Tel.: +1 631 4154758
Hauppauge, NY 11788 sales@sonotecusa.com
USA www.sonotecusa.com