



The compact inline sensor **SONOFLOW® IL.52/3 V2.0** serves to quickly detect smallest flow rates of liquids. Constructed as a built-in component for machines and apparatuses, the sensor can easily be mechanically installed and electrically integrated into the control system. Due to the current, frequency and switching outputs industrial dosing applications can be supported. The RS-485 interface (SONOTEC® protocol; Modbus® via software settings) allows bus operation of up to 12 sensors in rough industrial environments. Specifically designed for the use in areas with rigorous hygiene requirements, the sensor is suitable for circulation cleaning, steam sterilization and autoclaving.

## General data

SONOFLOW® IL.52/3 V2.0 Ultrasonic Flow Sensor for Liquids		
Order-No.	IL.52/3 PEEK / Viton®	200 08 0001
	IL.52/3 PEEK / FFKM	200 08 0044
Dimensions (L × W × H)	148 × 59 × 46 mm	
Weight	370 g	
Media	Water or other acoustically transparent, low-viscosity liquids (for applications with high-viscosity liquids, e.g. fats / special paints, screening tests must be made)	
Upper range value	3 000 ml/min	
Accuracy for water (at 23° C ± 2 K and 1 bar)	0 ... 30 ml/min: ± 0.3 ml/min	
	30 ... 3 000 ml/min: ± 1.0 %	
Calibration	Factory calibrated for water at 23 °C ± 2 K, outlet of the tubes depressurized (0 bar), other calibration on request	
Zero stability	0.375 ml/min	
Max. pressure drop	0.95 bar at a flow rate of 3 000 ml/min (value dependent on flow rate, with lower readings accordingly reduced)	

Modbus® is a registered trademark of Schneider Electric and is licensed by the Modbus Organization, Inc.  
Viton® is a registered trademark of DuPont de Nemours, Inc.

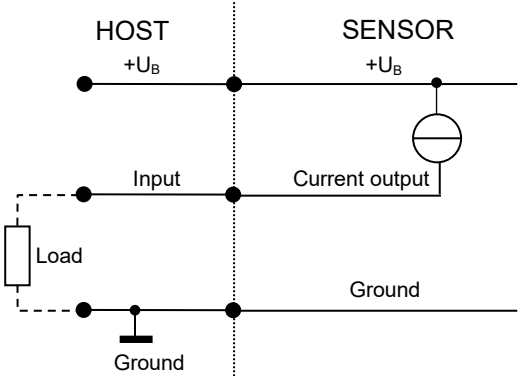
<b>Measuring method</b>	Ultrasound, time of flight measurement
<b>Measuring cycle</b>	Typical 20 ms (minimum 4 ms)
<b>Indirect temperature measurement</b>	Integrated sensor at the inlet (accuracy of temperature sensor $\pm 1$ °C, with $T_{\text{ambient}}$ 23 °C and Q 1 l/min)
<b>Mounting</b>	Fixed installation: 4 × recessed threaded holes M5, depth: 10 mm
<b>Measuring channel</b>	Ø 3.0 mm
<b>Adaptor for tube connection</b>	Outer diameter 8 mm, inner diameter 4 mm, material: PEEK
<b>Max. pressure</b>	10 bar
<b>Material</b>	In contact with fluid: Measuring channel and cell: PEEK, Seals: Viton® / FFKM Side plates: stainless steel; Connector: PA black, Pins: brass
<b>Operating voltage</b>	12 ... 30 VDC, ripple max. 10 %, protection against reverse polarity (external fuse, if required: min. 200 mA)
<b>Current consumption</b>	Maximum 50 mA (with open current, frequency and switching output, depending on supply voltage)
<b>Electrical connection</b>	8 pin M12 connector, DIN EN 61076-2-101:2013
<b>Shielding</b>	Required: via cable / housing (mounting screws)
<b>Interfaces</b>	<ul style="list-style-type: none"> <li>• Current output for flow rate: 0/4 ... 20 mA</li> <li>• Frequency output for flow rate: 0 ... 20 kHz, 5 V digital</li> <li>• RS-485 interface: bus-capable (SONOTEC® protocol, optional Modbus®)</li> <li>• Switching output: configurable as PNP / NPN / Push-Pull, 0 ... 30 V</li> <li>• Digital input</li> </ul>
<b>Current output for flow rate</b>	<p>⚠ <b>NOTE:</b> Load to GND. The max. load depends on the operating voltage: 12 V → 250 Ω, 15 V → 500 Ω, 24 V → 1 kΩ, 30 V → 1.2 kΩ</p> 

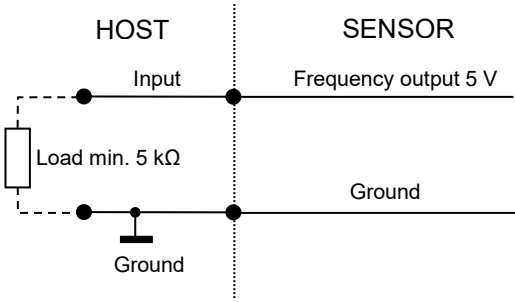
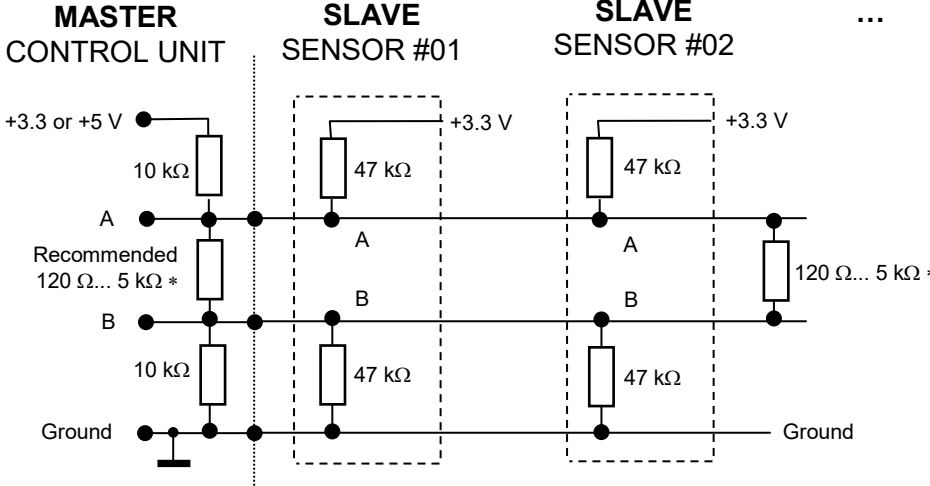
<p><b>Frequency output for flow rate</b></p>	
<p><b>RS-485 interface</b></p>	<p>SONOTEC® protocol: Half-duplex operation / 115.200 baud / no parity / 1 stop bit / no handshaking (Modbus® via software settings)</p> <p>⚠ <b>NOTE:</b> Please find the description of the serial protocol for details (upon request).</p> <p>Recommended electrical connection of the RS-485 interface</p> <p>⚠ <b>CAUTION!</b> If the interface is not used, it does not necessarily has to be connected; the two pins A and B can remain open.</p>  <p>* According to bus standard: depending on number of sensors and cable length</p>
<p><b>RS-485 Bus operation</b></p>	<p>The sensor supports bus operation with max. 12 subscribers. The default address is #01.</p> <p>⚠ <b>NOTE:</b> The address can be changed by software settings (see opt. accessories). Permitted are addresses from #01 ... #12. → Menu: Identification   RS-485 address</p>
<p><b>Switching output</b></p>	<p>Freely configurable: e.g. adapting batch process or threshold switch of flow, maximum 100 mA</p>

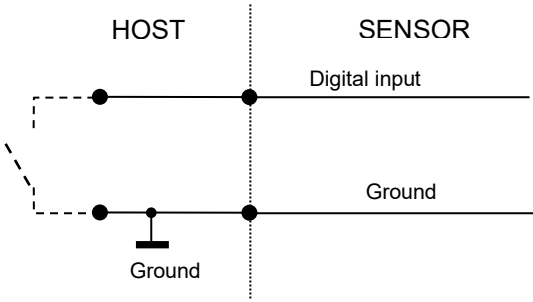
<b>Digital input</b>	<p>Freely configurable: for example for zero point calibration of flow or start dosing processes Voltage resistant up to 30 V</p> 
<b>Protection class</b>	IP65
<b>Cleaning and sterilization</b>	<ul style="list-style-type: none"> <li>• Maximum liquid temperature: temporarily +145 °C; Resistant to cleaning agents (e.g. caustic soda or 3 percent nitric acid)</li> <li>• Autoclavable: for max. 5 cycles of 30 minutes at 121 °C</li> </ul> <p>⚠ <b>NOTE:</b> Before the cleaning, verify that the sensor materials (PEEK, Viton® / FFKM) are resistant against the cleaning agent.</p>
<b>Media temperature</b>	0 ... +100 °C (T > 70 °C without voltage, temporarily +145 °C)
<b>Ambient temperature</b>	0 ... +70 °C
<b>Storage temperature</b>	-20 ... +70 °C
<b>Directives and standards</b>	<ul style="list-style-type: none"> <li>• EMC directive 2014/30/EU</li> <li>• RoHS: 2011/65/EU, exception: III 7cI/ IV 15</li> <li>• Acoustic emission: IEC 61157</li> </ul>
<b>Maintenance</b>	Maintenance-free
<b>Scope of delivery</b>	<ul style="list-style-type: none"> <li>• SONOFLOW® IL.52/3 V2.0 according to specification</li> <li>• User documentation</li> </ul>
<b>Optional accessories</b>	<ul style="list-style-type: none"> <li>• 8-pole M12 sensor cable, length 2 m / 5 m</li> <li>• Calibration protocol</li> </ul> <p>SONOFLOW® C<sup>3</sup> Software – for setting parameters, to adjust sensors for a specific application and for recording measurements; Consisting of:</p> <ul style="list-style-type: none"> <li>• USB Data Converter, type 013 for the connection to a computer</li> <li>• USB cable, type A-B, length 2 m</li> <li>• 8-pole M12 connecting cable, length 2 m</li> <li>• Switching power supply (12 VDC)</li> <li>• USB flash drive with SONOFLOW® C<sup>3</sup> Software and driver for Windows</li> </ul>

**Electrical connection**

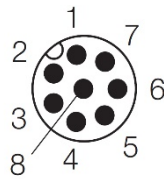

Male connector  
(at the sensor)

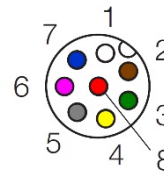

Female connector  
(at the cable)

M12 connecting cable	Pin	Color	Connection
<b>Assignment</b>	1	White	Ground
	2	Brown	Operating voltage +12 ... 30 VDC
	3	Green	Current output (0/4 ... 20 mA)
	4	Yellow	RS-485 B
	5	Grey	RS-485 A
	6	Pink	Frequency output 0 ... 20 kHz
	7	Blue	Switching output: PNP / NPN / Push-Pull
	8	Red	Digital input

Technical drawings

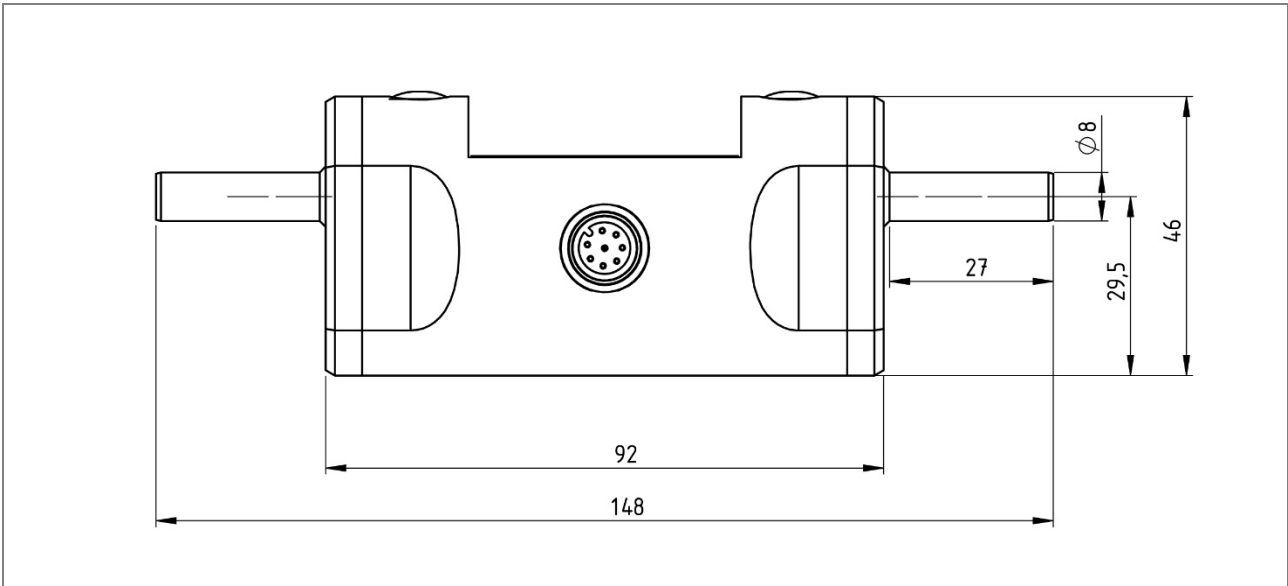

Figure 1: Dimensions SONOFLOW® IL.52/3 V2.0 – Side view

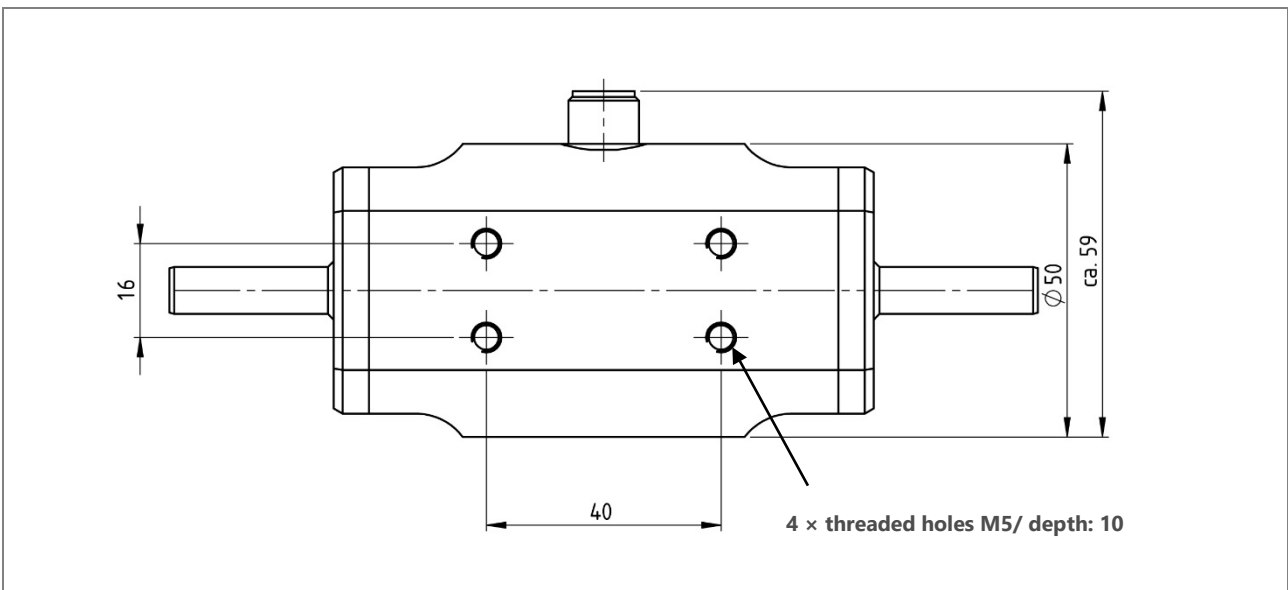

Figure 2: Rear side with drill holes for mounting

All figures and drawings are not to scale. Dimensions in mm, unless otherwise specified. Information is subject to change without notice.

**MANUFACTURER**  
SONOTEC GmbH  
  
www.sonotec.eu

**U-F-M B.V.**  
Argon 24  
4751XC Oud-Gastel  
The Netherlands  
T +31 (0) 165 855 655  
E info@u-f-m.nl  
www.u-f-m.nl

Official Sonotec dealer in The Netherlands:

