

## **UFM-50 Doppler Flow Meter**

**for Accurate Flow Measurement from outside a pipe**



### **Model UFM-50 Displays, Transmits, Totalizes and Controls**

- User-friendly
- Calibration password protected
- isolated 4-20mA output
- 2 Control relays
- Digital signal
- Processing optional
- Intrinsic safety

**Ideal for “Problem Liquids” more than 10 % Solids or air bubbles**  
**External Sensor**  
**No Contact, No Maintenance**

UFM-50 Doppler Flow Meters monitor the flow rate of dirty or aerated liquids including: wastewater, chemicals, acids, slurries, abrasives and viscous liquids. Recommended for full pipes and any fluid that contains solids or bubbles.

The UFM-50 strap-on sensor is mounted on the outside of a plastic or metal pipe ½ inch / 12.7 mm diameter or larger. To measure flow an acoustic signal is reflected back to the sensor from moving particles or gas bubbles suspended in the fluid.

Installation is easy - without shutting down the flow system. No contact is made with the moving fluid and no pipe cutting or drilling is required. There is no fouling or scale build-up on the sensor.

The UFM-50 Doppler Flow Meter includes an ultrasonic sensor, a simple 5-key calibration system, a large digital flow rate display with totalizer, isolated 4-20mA output and two programmable control relays. Data logger and intrinsically safe sensor are optional.

# UFM-50 Doppler Flow Meter

## Measures Flow with Clamp-on Ultrasonic Sensor Designed for “difficult” liquids

The UFM-50 Doppler flow meter works best in applications that would defeat regular contacting flow meters. Because the Sensor is mounted on the outside of the pipe, it is unaffected by abrasives or harsh chemicals. There is no obstruction to flow and no pressure drop.

### **Easy to Install**

Each UFM-50 Doppler Flow Meter includes a clamp-on ultrasonic sensor, an adjustable stainless steel mounting clamp and sensor coupling compound. The sensor fits on the outside of any pipe diameter ½" (12.7 mm) or larger. It takes just a few minutes to install. There is no need to shut down flow.



*Easy to install*

### **Simple, Single-Head Sensor design**

Ultrasonic signals are transmitted and received from a single-head sensor. The mounting clamp (included) ensures correct sensor alignment on horizontal or vertical pipes. The UFM-50 automatically self-tunes to the cable length up to 500 ft. (152 m).

### **Works on most Pipes**

The UFM-50 Doppler Flow Meter measures flow in PVC, carbon steel, stainless steel, cast iron, fiberglass, and lined pipes... any pipe material that conducts ultrasound. Doppler signals cannot transmit through pipe walls which contain air pockets (e.g. concrete or wood), or loose pipe liners (with an air gap between the liner and pipe wall).

### **Backlit Matrix Display with Simple, 5-key Menu System**

Calibration is easy with the UFM-50 user-friendly menu system. Press the arrow keys to scroll through menus, change settings and enter calibration values. You can select English, French or Spanish menus, enable a password to protect settings and control brightness of the digital display.

### **Reverse Flow Measurement**

The UFM-50 measures flow in either direction and displays positive or negative values. You can control the Totalizer to subtract reverse flow, or to totalize forward flow only. The 4mA setting can also be adjusted to a negative flow setting.

### **Optional Data Logger with USB Thumb Drive Support**

Order your UFM-50 Doppler Flow Meter with an optional built-in 2 million point data logger. It includes Windows software to display flow charts and tables, and to create dynamic flow reports. Just plug in a standard USB flash drive and log files are downloaded automatically - and fast!

### **Principle of Operation**

The UFM-50 Sensor transmits continuous high frequency sound through the pipe wall into the flowing liquid.

Sound is reflected back to the Sensor from particles or gas bubbles in the liquid. If the liquid is flowing, the reflected sound returns at an altered frequency (the Doppler effect). The Finch UFM-50 continuously measures this frequency shift to accurately measure flow.

### **Enhanced Signal Processing for reliable Accuracy**

The UFM-50 Doppler flow algorithm filters out background noise and interference. The digital signal processor discriminates against weak and distorted signals. When the processor cannot measure accurately the meter will display zero flow.

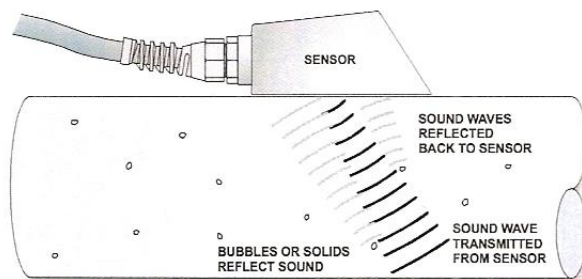

*Principle of operation*

## Specifications

**Flow Rate Range:**  $\pm 0.1$  to 40 ft/sec ( $\pm 0.03$  to 12.2 m/sec) in most applications

**Pipe Size:** Any pipe ID from 1/2" to 180" (12.7 mm to 4.5 m)

**Accuracy:**  $\pm 2\%$  of scale. Requires solids or bubbles minimum size of 100 microns, minimum concentration 75 ppm. Repeatability:  $\pm 0.1\%$ , Linearity  $\pm 0.5\%$  of full scale

**Display:** White, backlit matrix - displays flow rate, relay states, 16-digit totalizer, operating mode and calibration menu

**Calibration:** built-in 5-key calibrator with English, French or Spanish language selection

**Power Input:** 100-240VAC 50-60Hz (see Options), 5 Watts maximum (with standard features)

**Output:** Isolated 4-20mA (1000 ohm load max.)

**Control Relays:** Qty 2, rated 5 amp SPDT, programmable flow alarm and/or proportional pulse

**Enclosure:** watertight, dust tight NEMA4X (IP 66) polyester with a clear polycarbonate face

**Electronics Operating Temperature:** -10° to 140°F (-23° to 60°C)

**Sensitivity:** adjustable. Damping: adjustable

**Electrical Surge Protection:** Sensor, 4-20mA output and AC power input

**Shipping Weight:** 14 lbs (6.3 kg)

### Sensor:

**Sensor Model SE4** single-head ultrasonic with 20 ft (6 m) shielded cable and stainless steel mounting kit for pipes 1/2" (12.7 mm) ID or larger. Designed to withstand accidental submersion to 10 psi.

Certified non-incendive for Class I Division 2, Groups A,B,C,D hazardous locations

**Sensor Operating Temperature:** -40° to 300°F (-40° to 150°C)

### Options:

**Sensors:** Intrinsic Safety Barriers for Sensor mounting in Class 1 Div.1 hazardous locations

**Sensor Cable:** 50 ft. (15 m) or 100 ft. (30 m) continuous shielded coaxial pair, or splice up to 500 ft (152 m) with Junction Box. Self tunes to extended cable

**Enclosure Heater:** for outdoor installation, 16 watt thermostatically controlled to -40°F (-40°C)

**Data Logger:** Built-in 2 million point logger with USB output and Windows™ software

**Power input:** 9-32VDC

**Control Relays:** 4 additional (6 total) rated 5 ampere SPDT

### Applications:

**Recommended for:** liquids containing suspended solids or bubbles minimum size of 100 microns, minimum concentration 75 ppm. Sensor mounts on Vertical or Horizontal pipes

**Sensor Mounting Location:** 6-10 pipe diameters from elbows, tees (turbulence increasing devices) and >30 pipe diameters from pumps, controlling valves and pipe discharge

### Pipe Materials:

steel, stainless steel, cast iron, PVC, fiberglass, any contiguous pipe material that conducts sound, including lined pipes with liner bonded to pipe wall. Avoid pipes with loose insertion liners and pipe walls which contain air (concrete, wood etc.)

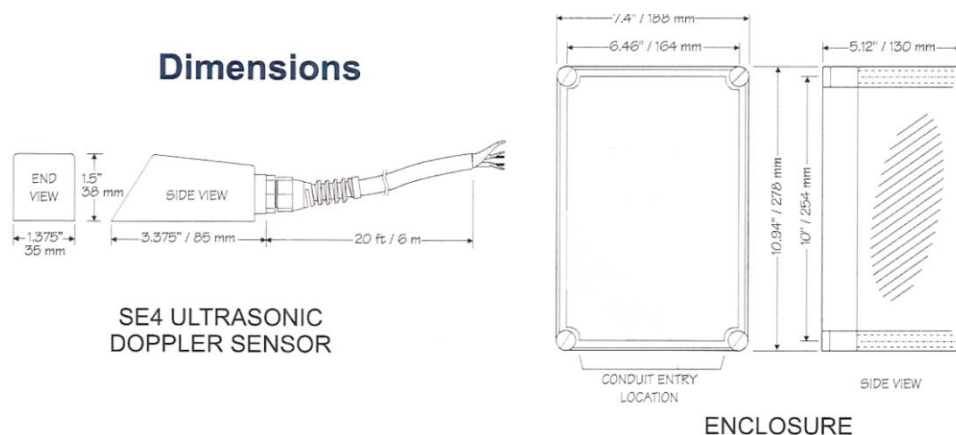

## Non-Contacting Doppler Flow Meter UFM-50 Monitors, displays, totalizes and controls from outside a pipe

### UFM-50 Doppler Flow Meter

The UFM-50 flow sensor installs without cutting the pipe. It takes just a few minutes to mount on the outside of any pipe. Calibration is easy with the built-in, 5-button keypad. Select your choice of flow units and enter pipe diameter through the user friendly calibration menu. Enable password protection to prevent tampering.

### Special Features

- Digital processing system tracks flow signals accurately and auto-zeroes with signal loss
- Noise suppression circuitry filters “dirty” power and electrical interference from most VFD's
- Automatically converts between measurement units (e.g. gallons or liters)
- Calibration data and Totalizer values are stored automatically during power interruptions
- Output “simulation” function simplifies calibration of remote devices (e.g. chart recorders or controllers)
- Self-tunes to Sensor cable length

### Benefits of Non-Contacting Flow Measurement

No Contact means no maintenance, no sensor fouling, no obstruction to flow, no pressure drop, no corrosion and no pipe cutting or drilling for installation.

### Designed for:

- Raw sewage
- Treated wastewater
- Viscous liquids
- Chemicals and Acids
- Sludge and Slurries
- Pulp stock
- Lubricating oils
- Crude oil
- Cooling water
- Solvents
- Food products

**Ideal for full pipes and any liquid containing gas bubbles or solids larger than 100 microns and in concentrations greater than 75 ppm.**



Fixed installation



Portable unit in case



Portable unit